

## System-Side Impedance Track™ Fuel Gauge With Direct Battery Connection

### FEATURES

- Single series cell Li-Ion battery fuel gauge resides on system board
  - Integrated 2.5 VDC LDO
  - External low-value 10 mΩ sense resistor
- Patented Impedance Track™ technology
  - Adjusts for battery aging, self-discharge, temperature, and rate changes
  - Reports Remaining Capacity, State of Charge (SOC), and Time-to-Empty
    - Optional Smoothing Filter
  - Battery State of Health (aging) estimation
  - Supports embedded or removable packs with up to 32Ahr capacity
    - Accommodates pack swapping with 2 separate battery profiles
- Microcontroller peripheral supports:
  - 400-kHz I<sup>2</sup>C™ serial interface
  - 32 Bytes of Scratch-Pad FLASH NVM
  - Battery Low digital output warning
  - Configurable SOC Interrupts
  - External thermistor, internal sensor, or host reported temperature options
- Small 12-pin 2,5 mm × 4 mm SON Package

### APPLICATIONS

- Smartphones, Feature phones and Tablets
- Digital Still and Video Cameras
- Handheld Terminals
- MP3 or Multimedia Players

### DESCRIPTION

The Texas Instruments bq27510-G3 system-side Li-Ion battery fuel gauge is a microcontroller peripheral that provides fuel gauging for single-cell Li-Ion battery packs. The device requires little system microcontroller firmware development. The bq27510-G3 resides on the system's main board and manages an embedded battery (non-removable) or a removable battery pack.

The bq27510-G3 uses the patented Impedance Track™ algorithm for fuel gauging, and provides information such as remaining battery capacity (mAh), state-of-charge (%), run-time to empty (min.), battery voltage (mV), temperature (°C) and state of health (%).

Battery fuel gauging with the bq27510-G3 requires only PACK+ (P+), PACK– (P–), and optional Thermistor (T) connections to a removable battery pack or embedded battery circuit.

### TYPICAL APPLICATION

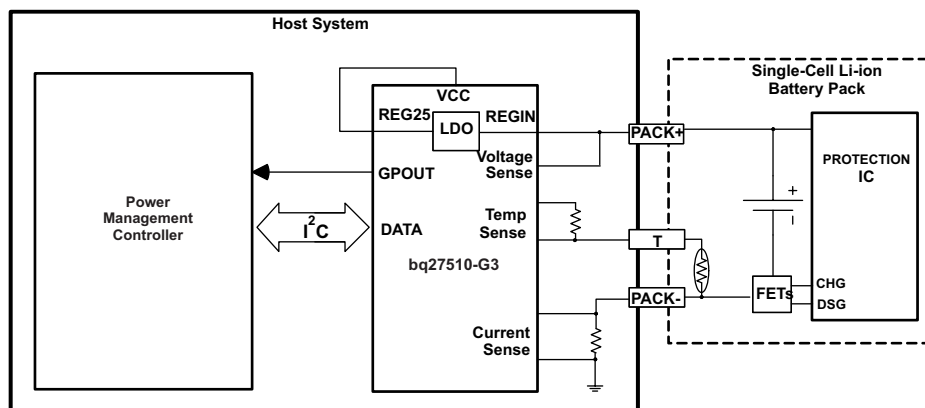

Please be aware that an important notice concerning availability, standard warranty, and use in critical applications of Texas Instruments semiconductor products and disclaimers thereto appears at the end of this data sheet.

Impedance Track is a trademark of Texas Instruments.

I<sup>2</sup>C is a trademark of Phillips Corporation.



These devices have limited built-in ESD protection. The leads should be shorted together or the device placed in conductive foam during storage or handling to prevent electrostatic damage to the MOS gates.

## DEVICE INFORMATION

### AVAILABLE OPTIONS

PART NUMBER	FIRMWARE VERSION	PACKAGE <sup>(1)</sup>	T <sub>A</sub>	COMMUNICATION FORMAT	TAPE and REEL QUANTITY
bq27510DRZR-G3	4.00 (0X0400)	12-pin, 2,5-mm × 4-mm SON	–40°C to 85°C	I <sup>2</sup> C	3000
bq27510DRZT-G3					250

(1) For the most current package and ordering information see the Package Option Addendum at the end of this document; or, see the TI website at [www.ti.com](http://www.ti.com).

### PIN DIAGRAM

**DRZ PACKAGE  
(TOP VIEW)**

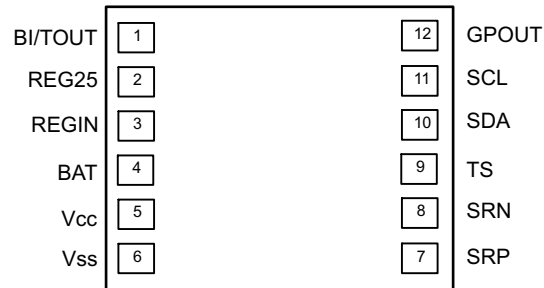

### PIN FUNCTIONS

PIN		TYPE <sup>(1)</sup>	DESCRIPTION
NAME	NO.		
BI/TOUT	1	I/O	Battery-insertion detection input. Power pin for pack thermistor network. Thermistor-multiplexer control pin. Open-drain I/O. Use with pull-up resistor >1MΩ (1.8 MΩ typical).
REG25	2	P	2.5 V output voltage of the internal integrated LDO.
REGIN	3	P	Regulator input. Decouple with 0.1μF ceramic capacitor to Vss.
BAT	4	I	Cell voltage measurement input. ADC input.
Vcc	5	P	Processor power input. Decouple with 0.1μF ceramic capacitor minimum.
Vss	6	P	Device ground
SRP	7	IA	Analog input pin connected to the internal coulomb counter with a Kelvin connection where SRP is nearest the PACK– connection. Connect to 5-mΩ to 20-mΩ sense resistor.
SRN	8	IA	Analog input pin connected to the internal coulomb counter with a Kelvin connection where SRN is nearest the Vss connection. Connect to 5-mΩ to 20-mΩ sense resistor.
TS	9	IA	Pack thermistor voltage sense (use 103AT-type thermistor). ADC input
SDA	10	I/O	Slave I <sup>2</sup> C serial communications data line for communication with system (Master). Open-drain I/O. Use with 10-kΩ pull-up resistor (typical).
SCL	11	I	Slave I <sup>2</sup> C serial communications clock input line for communication with system (Master). Open-drain I/O. Use with 10-kΩ pull-up resistor (typical).
GPOUT	12	O	General Purpose open-drain output. May be configured as Battery Low, Battery Good, or to perform interrupt functionality.

(1) I/O = Digital input/output; IA = Analog input; P = Power connection.

## ELECTRICAL SPECIFICATIONS

### ABSOLUTE MAXIMUM RATINGS

over operating free-air temperature range (unless otherwise noted)<sup>(1)</sup>

		VALUE		UNIT
		MIN	MAX	
V <sub>REGIN</sub>	Regulator input voltage	-0.3	24	V
V <sub>CC</sub>	Supply voltage range	-0.3	2.75	V
V <sub>IOD</sub>	Open-drain I/O pins (SDA, SCL, GPOUT)	-0.3	6	V
V <sub>BAT</sub>	BAT input pin	-0.3	6	V
V <sub>I</sub>	Input voltage range to all other pins (TS, SRP, SRN, BI/TOUT)	-0.3	V <sub>CC</sub> + 0.3	V
T <sub>F</sub>	Functional temperature range	-40	100	°C
T <sub>STG</sub>	Storage temperature range	-65	150	°C
ESD	Human Body Model (HBM), BAT pin		1.5	KV
	Human Body Model (HBM), all other pins		2	

(1) Stresses beyond those listed under *absolute maximum ratings* may cause permanent damage to the device. These are stress ratings only, and functional operation of the device at these or any other conditions beyond those indicated under *recommended operating conditions* is not implied. Exposure to absolute-maximum-rated conditions for extended periods may affect device reliability.

### THERMAL INFORMATION

THERMAL METRIC <sup>(1)</sup>		DRZ (12-PINS)	UNITS
θ <sub>JA</sub>	Junction-to-ambient thermal resistance	64.1	°C/W
θ <sub>JCtop</sub>	Junction-to-case (top) thermal resistance	59.8	
θ <sub>JB</sub>	Junction-to-board thermal resistance	52.7	
ψ <sub>JT</sub>	Junction-to-top characterization parameter	0.3	
ψ <sub>JB</sub>	Junction-to-board characterization parameter	28.3	
θ <sub>JCbot</sub>	Junction-to-case (bottom) thermal resistance	2.4	

(1) For more information about traditional and new thermal metrics, see the *IC Package Thermal Metrics* application report, [SPRA953](#).

### RECOMMENDED OPERATING CONDITIONS

T<sub>A</sub> = 25°C, V<sub>CC</sub> = 2.5 V (unless otherwise noted)

PARAMETER		TEST CONDITION	MIN	TYP	MAX	UNIT
V <sub>REGIN</sub>	Supply voltage	No operating restrictions	2.7		5.5	V
		No FLASH writes	2.45		2.7	
C <sub>REG25</sub>	External REG25 capacitor	C <sub>REG25</sub>	0.47			μF
t <sub>PUCD</sub>	Power Up Communication Delay			250		ms
I <sub>CC</sub>	Normal operating mode current	Fuel gauge in NORMAL mode, I <sub>LOAD</sub> > <b>Sleep Current</b>		103		μA
I <sub>SLP</sub>	Low-power operating mode current	Fuel gauge in SLEEP mode. I <sub>LOAD</sub> < <b>Sleep Current</b>		18		μA
I <sub>SLP+</sub>	Low-power operating mode current	Fuel gauge in SLEEP+ mode. I <sub>LOAD</sub> < <b>Sleep Current</b>		60		μA
I <sub>HIB</sub>	Hibernate operating mode current	Fuel gauge in HIBERNATE mode. I <sub>LOAD</sub> < <b>Hibernate Current</b>		4		μA
V <sub>OL</sub>	Output voltage low (SDA, GPOUT, BI/TOUT)	I <sub>OL</sub> = 0.5 mA			0.4	V
V <sub>OH(PP)</sub>	Output high voltage (GPOUT)	I <sub>OH</sub> = -1 mA	V <sub>CC</sub> -0.5			V
V <sub>OH(OD)</sub>	Output high voltage (SDA, SCL, BI/TOUT)	External pull-up resistor connected to V <sub>CC</sub>	V <sub>CC</sub> -0.5			V
V <sub>IL</sub>	Input voltage low (SDA, SCL)		-0.3		0.6	V
	Input voltage low (BI/TOUT)	BAT INSERT CHECK MODE active	-0.3		0.6	
V <sub>IH(OD)</sub>	Input voltage high (SDA, SCL)		1.2		6	V
	Input voltage high (BI/TOUT)	BAT INSERT CHECK MODE active	1.2		6	
V <sub>A1</sub>	Input voltage range (TS)		V <sub>SS</sub> -0.125		2	V
V <sub>A2</sub>	Input voltage range (BAT)		V <sub>SS</sub> -0.125		5	V

## RECOMMENDED OPERATING CONDITIONS (continued)

$T_A = 25^\circ\text{C}$ ,  $V_{CC} = 2.5\text{ V}$  (unless otherwise noted)

PARAMETER		TEST CONDITION	MIN	TYP	MAX	UNIT
$V_{A3}$	Input voltage range (SRP, SRN)		$V_{SS}-0.125$		0.125	V
$t_{PUCD}$	Power-up communication delay			250		ms
$T_A$	Operating free-air temperature range		-40		85	$^\circ\text{C}$

## 2.5 V LDO (1)

$T_A = 25^\circ\text{C}$ ,  $C_{REG} = 0.47\ \mu\text{F}$ ,  $V_{REGIN} = 3.6\text{ V}$  (unless otherwise noted)

PARAMETER		TEST CONDITION	MIN	NOM	MAX	UNIT	
$V_{REG25}$	Regulator output voltage	$2.7\text{ V} \leq V_{REGIN} \leq 5.5\text{ V}$ , $I_{OUT} \leq 16\text{ mA}$	$T_A = -40^\circ\text{C}$ to $85^\circ\text{C}$	2.4	2.5	2.6	V
		$2.45\text{ V} \leq V_{REGIN} < 2.7\text{ V}$ (low battery), $I_{OUT} \leq 3\text{ mA}$	$T_A = -40^\circ\text{C}$ to $85^\circ\text{C}$	2.40			V
$V_{DO}$	Regulator dropout voltage	$2.7\text{ V}$ , $I_{OUT} \leq 16\text{ mA}$	$T_A = -40^\circ\text{C}$ to $85^\circ\text{C}$		280		mV
		$2.45\text{ V}$ , $I_{OUT} \leq 3\text{ mA}$			50		
$\Delta V_{REGTEMP}$	Regulator output change with temperature	$V_{REGIN} = 3.6\text{ V}$ , $I_{OUT} = 16\text{ mA}$	$T_A = -40^\circ\text{C}$ to $85^\circ\text{C}$	0.3%			
$\Delta V_{REGLINE}$	Line regulation	$2.7\text{ V} \leq V_{REGIN} \leq 5.5\text{ V}$ , $I_{OUT} = 16\text{ mA}$		11	25	mV	
$\Delta V_{REGLOAD}$	Load regulation	$0.2\text{ mA} \leq I_{OUT} \leq 3\text{ mA}$ , $V_{REGIN} = 2.45\text{ V}$		34	40	mV	
		$3\text{ mA} \leq I_{OUT} \leq 16\text{ mA}$ , $V_{REGIN} = 2.7\text{ V}$		31			
$I_{SHORT}^{(2)}$	Short circuit current limit	$V_{REG25} = 0\text{ V}$	$T_A = -40^\circ\text{C}$ to $85^\circ\text{C}$		250	mA	

(1) LDO output current,  $I_{OUT}$ , is the sum of internal and external load currents.

(2) Assured by design. Not production tested.

## POWER-ON RESET

$T_A = -40^\circ\text{C}$  to  $85^\circ\text{C}$ , typical values at  $T_A = 25^\circ\text{C}$  and  $V_{BAT} = 3.6\text{ V}$  (unless otherwise noted)

PARAMETER		TEST CONDITIONS	MIN	TYP	MAX	UNIT
$V_{IT+}$	Positive-going battery voltage input at $V_{CC}$		2.05	2.20	2.31	V
$V_{HYS}$	Power-on reset hysteresis		45	115	185	mV

## INTERNAL TEMPERATURE SENSOR CHARACTERISTICS

$T_A = -40^\circ\text{C}$  to  $85^\circ\text{C}$ ,  $2.4\text{ V} < V_{CC} < 2.6\text{ V}$ ; typical values at  $T_A = 25^\circ\text{C}$  and  $V_{CC} = 2.5\text{ V}$  (unless otherwise noted)

PARAMETER		TEST CONDITIONS	MIN	TYP	MAX	UNIT
$G_{TEMP}$	Temperature sensor voltage gain			-2		mV/ $^\circ\text{C}$

## INTERNAL CLOCK OSCILLATORS

$T_A = -40^\circ\text{C}$  to  $85^\circ\text{C}$ ,  $2.4\text{ V} < V_{CC} < 2.6\text{ V}$ ; typical values at  $T_A = 25^\circ\text{C}$  and  $V_{CC} = 2.5\text{ V}$  (unless otherwise noted)

PARAMETER		TEST CONDITIONS	MIN	TYP	MAX	UNIT
$f_{OSC}$	High Frequency Oscillator			8.389		MHz
$f_{LOSC}$	Low Frequency Oscillator			32.768		kHz

## INTEGRATING ADC (COULOMB COUNTER) CHARACTERISTICS

$T_A = -40^\circ\text{C}$  to  $85^\circ\text{C}$ ,  $2.4\text{ V} < V_{CC} < 2.6\text{ V}$ ; typical values at  $T_A = 25^\circ\text{C}$  and  $V_{CC} = 2.5\text{ V}$  (unless otherwise noted)

PARAMETER		TEST CONDITIONS	MIN	TYP	MAX	UNIT
$V_{SR\_IN}$	Input voltage range, $V_{(SRN)}$ and $V_{(SRP)}$	$V_{SR} = V_{(SRN)} - V_{(SRP)}$	-0.125		0.125	V
$t_{SR\_CONV}$	Conversion time	Single conversion		1		s
	Resolution		14		15	bits
$V_{SR\_OS}$	Input offset			10		$\mu\text{V}$
$I_{NL}$	Integral nonlinearity error			$\pm 0.007$	$\pm 0.034$	%FSR

## INTEGRATING ADC (COULOMB COUNTER) CHARACTERISTICS (continued)

$T_A = -40^\circ\text{C}$  to  $85^\circ\text{C}$ ,  $2.4\text{ V} < V_{CC} < 2.6\text{ V}$ ; typical values at  $T_A = 25^\circ\text{C}$  and  $V_{CC} = 2.5\text{ V}$  (unless otherwise noted)

PARAMETER		TEST CONDITIONS	MIN	TYP	MAX	UNIT
$Z_{SR\_IN}$	Effective input resistance <sup>(1)</sup>		2.5			M $\Omega$
$I_{SR\_LKG}$	Input leakage current <sup>(1)</sup>				0.3	$\mu\text{A}$

(1) Assured by design. Not production tested.

## ADC (TEMPERATURE AND CELL MEASUREMENT) CHARACTERISTICS

$T_A = -40^\circ\text{C}$  to  $85^\circ\text{C}$ ,  $2.4\text{ V} < V_{CC} < 2.6\text{ V}$ ; typical values at  $T_A = 25^\circ\text{C}$  and  $V_{CC} = 2.5\text{ V}$  (unless otherwise noted)

PARAMETER		TEST CONDITIONS	MIN	TYP	MAX	UNIT
$V_{ADC\_IN}$	Input voltage range		-0.2		1	V
$t_{ADC\_CONV}$	Conversion time				125	ms
	Resolution		14		15	bits
$V_{ADC\_OS}$	Input offset			1		mV
$Z_{ADC1}$	Effective input resistance (TS) <sup>(1)</sup>		8			M $\Omega$
$Z_{ADC2}$	Effective input resistance (BAT) <sup>(1)</sup>	bq27510-G3 not measuring cell voltage	8			M $\Omega$
		bq27510-G3 measuring cell voltage		100		k $\Omega$
$I_{ADC\_LKG}$	Input leakage current <sup>(1)</sup>				0.3	$\mu\text{A}$

(1) Assured by design. Not production tested.

## DATA FLASH MEMORY CHARACTERISTICS

$T_A = -40^\circ\text{C}$  to  $85^\circ\text{C}$ ,  $2.4\text{ V} < V_{CC} < 2.6\text{ V}$ ; typical values at  $T_A = 25^\circ\text{C}$  and  $V_{CC} = 2.5\text{ V}$  (unless otherwise noted)

PARAMETER		TEST CONDITIONS	MIN	TYP	MAX	UNIT
$t_{DR}$	Data retention <sup>(1)</sup>		10			Years
	Flash programming write-cycles <sup>(1)</sup>		20,000			Cycles
$t_{WORDPROG}$	Word programming time <sup>(1)</sup>				2	ms
$I_{CCPROG}$	Flash-write supply current <sup>(1)</sup>			5	10	mA

(1) Assured by design. Not production tested.

### 400 kHz I<sup>2</sup>C-COMPATIBLE INTERFACE COMMUNICATION TIMING CHARACTERISTICS

T<sub>A</sub> = -40°C to 85°C, 2.4 V < V<sub>CC</sub> < 2.6 V; typical values at T<sub>A</sub> = 25°C and V<sub>CC</sub> = 2.5 V (unless otherwise noted)

PARAMETER		TEST CONDITIONS	MIN	TYP	MAX	UNIT
t <sub>r</sub>	SCL/SDA rise time				300	ns
t <sub>f</sub>	SCL/SDA fall time				300	ns
t <sub>w(H)</sub>	SCL pulse width (high)		600			ns
t <sub>w(L)</sub>	SCL pulse width (low)		1.3			µs
t <sub>su(STA)</sub>	Setup for repeated start		600			ns
t <sub>d(STA)</sub>	Start to first falling edge of SCL		600			ns
t <sub>su(DAT)</sub>	Data setup time		100			ns
t <sub>h(DAT)</sub>	Data hold time		0			ns
t <sub>su(STOP)</sub>	Setup time for stop		600			ns
t <sub>BUF</sub>	Bus free time between stop and start		66			µs
f <sub>SCL</sub>	Clock frequency				400	kHz

### 100 kHz I<sup>2</sup>C-COMPATIBLE INTERFACE COMMUNICATION TIMING CHARACTERISTICS

T<sub>A</sub> = -40°C to 85°C, 2.4 V < V<sub>CC</sub> < 2.6 V; typical values at T<sub>A</sub> = 25°C and V<sub>CC</sub> = 2.5 V (unless otherwise noted)

PARAMETER		TEST CONDITIONS	MIN	TYP	MAX	UNIT
t <sub>r</sub>	SCL/SDA rise time				1	µs
t <sub>f</sub>	SCL/SDA fall time				300	ns
t <sub>w(H)</sub>	SCL pulse width (high)		4			µs
t <sub>w(L)</sub>	SCL pulse width (low)		4.7			µs
t <sub>su(STA)</sub>	Setup for repeated start		4.7			µs
t <sub>d(STA)</sub>	Start to first falling edge of SCL		4			µs
t <sub>h(DAT)</sub>	Data hold time	Receive mode	0			ns
		Transmit mode	300			
t <sub>su(DAT)</sub>	Data setup time		250			ns
t <sub>su(STOP)</sub>	Setup time for stop		4			µs
t <sub>BUF</sub>	Bus free time between stop and start		4.7			µs
f <sub>SCL</sub>	Clock frequency		10		100	kHz
t <sub>BUSERR</sub>	Bus error timeout		17.3		21.2	s

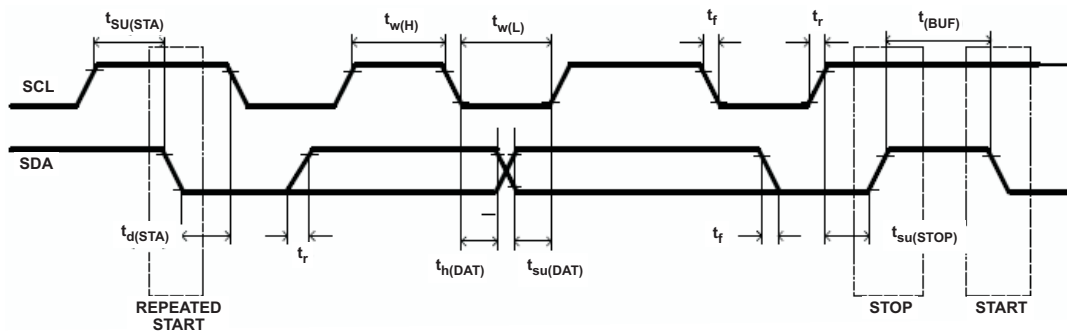

Figure 1. I<sup>2</sup>C-Compatible Interface Timing Diagrams

## GENERAL DESCRIPTION

The bq27510-G3 fuel gauge accurately predicts the battery capacity and other operational characteristics of a single Li-based rechargeable cell. It can be interrogated by a system processor to provide cell information, such as time-to-empty (TTE) and state-of-charge (SOC) as well as SOC interrupt signal to the host.

Information is accessed through a series of commands, called *Standard Commands*. Further capabilities are provided by the additional *Extended Commands* set. Both sets of commands, indicated by the general format *Command( )*, read and write information contained within the device control and status registers, as well as its data flash locations. Commands are sent from system to gauge using the I<sup>2</sup>C serial communications engine, and can be executed during application development, system manufacture, or end-equipment operation.

Cell information is stored in the device in non-volatile flash memory. Many of these data flash locations are accessible during application development. They cannot, generally, be accessed directly during end-equipment operation. Access to these locations is achieved by either use of the fuel gauge companion evaluation software, through individual commands, or through a sequence of data-flash-access commands. To access a desired data flash location, the correct data flash subclass and offset must be known.

The key to the fuel gauge high-accuracy gas gauging prediction is Texas Instruments proprietary Impedance Track™ algorithm. This algorithm uses cell measurements, characteristics, and properties to create state-of-charge predictions that can achieve less than 1% error across a wide variety of operating conditions and over the lifetime of the battery.

The fuel gauge measures charge and discharge activity by monitoring the voltage across a small-value series sense resistor (5 mΩ to 20 mΩ, typical) located between the system V<sub>SS</sub> and the battery PACK– terminal. When a cell is attached to the device, cell impedance is learned, based on cell current, cell open-circuit voltage (OCV), and cell voltage under loading conditions.

The external temperature sensing is optimized with the use of a high-accuracy negative temperature coefficient (NTC) thermistor with R<sub>25</sub> = 10.0 kΩ ± 1%. B<sub>25/85</sub> = 3435 kΩ ± 1% (such as Semitec NTC 103AT). Alternatively, the fuel gauge can also be configured to use its internal temperature sensor or receive temperature data from the host processor. When an external thermistor is used, a 18.2-kΩ pull-up resistor between BI/TOUT and TS pins is also required. The fuel gauge uses temperature to monitor the battery-pack environment, which is used for fuel gauging and cell protection functionality.

To minimize power consumption, the fuel gauge has several power modes: NORMAL, SLEEP, HIBERNATE, and BAT INSERT CHECK. The fuel gauge passes automatically between these modes, depending upon the occurrence of specific events, though a system processor can initiate some of these modes directly.

For complete operational details, refer to [bq27510-G3 Technical Reference Manual](#).

### Formatting conventions used in this document:

Information Type	Formatting Convention	Example
Commands	<i>Italics</i> with parentheses and no breaking spaces	<i>RemainingCapacity( )</i> command
NVM Data	<i>Italics</i> , <b>bold</b> , and breaking spaces	<b>Design Capacity</b> data
Register bits and flags	Brackets and <i>italics</i>	[TDA] bit
NVM Data bits	Brackets, <i>italics</i> , and <b>bold</b>	[ <b>LED1</b> ] bit
Modes and states	ALL CAPITALS	UNSEALED mode

## DATA COMMANDS

### STANDARD DATA COMMANDS

The bq27510-G3 fuel gauge uses a series of 2-byte standard commands to enable system reading and writing of battery information. Each standard command has an associated command-code pair, as indicated in [Table 1](#). Because each command consists of two bytes of data, two consecutive I<sup>2</sup>C transmissions must be executed both to initiate the command function, and to read or write the corresponding two bytes of data. Additional options for transferring data are described in Section of [COMMUNICATIONS](#). Standard commands are accessible in NORMAL operation. Read and write permissions depend on the active access mode, SEALED or UNSEALED. Additional details are found in the [bq27510-G3 Technical Reference Manual](#).

**Table 1. Standard Commands**

NAME	COMMAND CODE	UNITS	SEALED ACCESS
<i>Control( )</i>	0x00 / 0x01	N/A	R/W
<i>AtRate( )</i>	0x02 / 0x03	mA	R/W
<i>AtRateTimeToEmpty( )</i>	0x04 / 0x05	Minutes	R
<i>Temperature( )</i>	0x06 / 0x07	0.1 K	R/W
<i>Voltage( )</i>	0x08 / 0x09	mV	R
<i>Flags( )</i>	0x0a / 0x0b	N/A	R
<i>NominalAvailableCapacity( )</i>	0x0c / 0x0d	mAh	R
<i>FullAvailableCapacity( )</i>	0x0e / 0x0f	mAh	R
<i>RemainingCapacity( )</i>	0x10 / 0x11	mAh	R
<i>FullChargeCapacity( )</i>	0x12 / 0x13	mAh	R
<i>AverageCurrent( )</i>	0x14 / 0x15	mA	R
<i>TimeToEmpty( )</i>	0x16 / 0x17	Minutes	R
<i>StandbyCurrent( )</i>	0x18 / 0x19	mA	R
<i>StandbyTimeToEmpty( )</i>	0x1a / 0x1b	Minutes	R
<i>StateOfHealth( )</i>	0x1c / 0x1d	% / num	R
<i>CycleCount( )</i>	0x1e / 0x1f	num	R
<i>StateOfCharge( )</i>	0x20 / 0x21	%	R
<i>InstantaneousCurrent( )</i>	0x22 / 0x23	mA	R
<i>InternalTemperature( )</i>	0x28 / 0x29	0.1 K	R
<i>ResistanceScale( )</i>	0x2a / 0x2b		R
<i>OperationConfiguration( )</i>	0x2c / 0x2d	N/A	R
<i>DesignCapacity( )</i>	0x2e / 0x2f	mAh	R

**Control( ): 0x00/0x01**

Issuing a *Control( )* command requires a subsequent 2-byte subcommand. These additional bytes specify the particular control function desired. The *Control( )* command allows the system to control specific features of the fuel gauge during normal operation and additional features when the device is in different access modes, as described in [Table 2](#). Additional details are found in the [bq27510-G3 Technical Reference Manual](#).

**Table 2. Control( ) Subcommands**

CNTL FUNCTION	CNTL DATA	SEALED ACCESS	DESCRIPTION
CONTROL_STATUS	0x0000	Yes	Reports the status of DF checksum, hibernate, IT, etc.
DEVICE_TYPE	0x0001	Yes	Reports the device type (for example: 0x0520)
FW_VERSION	0x0002	Yes	Reports the firmware version on the device type
PREV_MACWRITE	0x0007	Yes	Returns previous <i>Control( )</i> subcommand code
CHEM_ID	0x0008	Yes	Reports the chemical identifier of the Impedance Track™ configuration
OCV_CMD	0x000C	Yes	Requests the fuel gauge to take an OCV measurement
BAT_INSERT	0x000D	Yes	Forces <i>Flags( )</i> [BAT_DET] bit set when <b>OpConfig B [BIE] = 0</b>
BAT_REMOVE	0x000E	Yes	Forces <i>Flags( )</i> [BAT_DET] bit clear when <b>OpConfig B [BIE] = 0</b>
SET_HIBERNATE	0x0011	Yes	Forces <i>CONTROL_STATUS</i> [HIBERNATE] to 1
CLEAR_HIBERNATE	0x0012	Yes	Forces <i>CONTROL_STATUS</i> [HIBERNATE] to 0
SET_SLEEP+	0x0013	Yes	Forces <i>CONTROL_STATUS</i> [SNOOZE] to 1
CLEAR_SLEEP+	0x0014	Yes	Forces <i>CONTROL_STATUS</i> [SNOOZE] to 0
DF_VERSION	0x001F	Yes	Returns the <b>Data Flash Version</b> code
SEALED	0x0020	No	Places the fuel gauge in SEALED access mode
IT_ENABLE	0x0021	No	Enables the Impedance Track™ (IT) algorithm
RESET	0x0041	No	Forces a full reset of the fuel gauge

## FUNCTIONAL DESCRIPTION

### FUEL GAUGING

The fuel gauge measures the cell voltage, temperature, and current to determine battery SOC. The fuel gauge monitors charge and discharge activity by sensing the voltage across a small-value (5 mΩ to 20 mΩ typ.) resistor between the SRP and SRN pins and in series with the cell. By integrating charge passing through the battery, the battery's SOC is adjusted during battery charge or discharge.

The total battery capacity is found by comparing states of charge before and after applying the load with the amount of charge passed. When an application load is applied, the impedance of the cell is measured by comparing the OCV obtained from a predefined function for present SOC with the measured voltage under load. Measurements of OCV and charge integration determine chemical state of charge and chemical capacity (Qmax). The initial Qmax values are taken from a cell manufacturers' data sheet multiplied by the number of parallel cells. It is also used for the value in **Design Capacity**. The fuel gauge acquires and updates the battery-impedance profile during normal battery usage. It uses this profile, along with SOC and the Qmax value, to determine *FullChargeCapacity()* and *StateOfCharge()*, specifically for the present load and temperature. *FullChargeCapacity()* is reported as capacity available from a fully charged battery under the present load and temperature until *Voltage()* reaches the **Terminate Voltage**. *NominalAvailableCapacity()* and *FullAvailableCapacity()* are the uncompensated (no or light load) versions of *RemainingCapacity()* and *FullChargeCapacity()* respectively.

The fuel gauge has two flags accessed by the *Flags()* function that warns when the battery's SOC has fallen to critical levels. When *StateOfCharge()* falls below the first capacity threshold, specified in **SOC1 Set Threshold**, the *[SOC1] (State of Charge Initial)* flag is set. The flag is cleared once *StateOfCharge()* rises above **SOC1 Clear Threshold**. The fuel gauge's GPOUT pin puts out 3 pulses 10ms wide and in 10ms intervals whenever the SOC1 flag is set. This flag is enabled when **RMC\_IND** bit in **Operation Configuration B** is set. This behavior also applies to the *[SOCF] (State of Charge Final)* flag.

When *Voltage()* falls below the system shut down threshold voltage, **SysDown Set Volt Threshold**, the *[SYSDOWN]* flag is set, serving as a final warning to shut down the system. The GPOUT also signals. When *Voltage()* rises above **SysDown Clear Voltage** and the *[SYSDOWN]* flag has already been set, the *[SYSDOWN]* flag is cleared. The GPOUT also signals such change. All units are in mV.

Additional details are found in the [bq27510-G3 Technical Reference Manual](#)

## COMMUNICATIONS

### I<sup>2</sup>C Interface

The bq27510-G3 fuel gauge supports the standard I<sup>2</sup>C read, incremental read, quick read, one byte write, and incremental write functions. The 7-bit device address (ADDR) is the most significant 7 bits of the hex address and is fixed as 1010101. The first 8-bits of the I<sup>2</sup>C protocol is, therefore, 0xAA or 0xAB for write or read, respectively.

Host generated     Gauge generated



(a) 1-byte write

(b) quick read

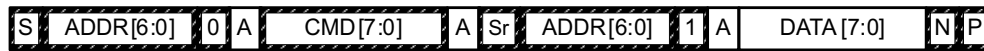

(c) 1- byte read

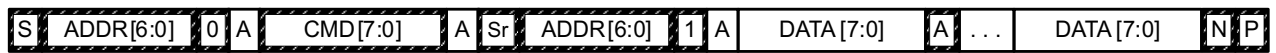

(d) incremental read



(e) incremental write

(S = Start, Sr = Repeated Start, A = Acknowledge, N = No Acknowledge, and P = Stop).

The “quick read” returns data at the address indicated by the address pointer. The address pointer, a register internal to the I<sup>2</sup>C communication engine, increments whenever data is acknowledged by the fuel gauge or the I<sup>2</sup>C master. “Quick writes” function in the same manner and are a convenient means of sending multiple bytes to consecutive command locations (such as two-byte commands that require two bytes of data)

The following command sequences are not supported:

Attempt to write a read-only address (NACK after data sent by master):

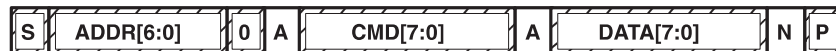

Attempt to read an address above 0x6B (NACK command):



### I<sup>2</sup>C Time Out

The I<sup>2</sup>C engine releases both SDA and SCL if the I<sup>2</sup>C bus is held low for 2 seconds. If the fuel gauge was holding the lines, releasing them frees them for the master to drive the lines. If an external condition is holding either of the lines low, the I<sup>2</sup>C engine enters the low-power sleep mode.

### I<sup>2</sup>C Command Waiting Time

To ensure proper operation at 400 kHz, a  $t_{(BUF)} \geq 66 \mu s$  bus free waiting time must be inserted between all packets addressed to the fuel gauge. In addition, if the SCL clock frequency ( $f_{SCL}$ ) is  $> 100 \text{ kHz}$ , use individual 1-byte write commands for proper data flow control. The following diagram shows the standard waiting time required between issuing the control subcommand and reading the status result. For read-write standard command, a minimum of 2 seconds is required to get the result updated. For read-only standard commands, there is no waiting time required, but the host should not issue all standard commands more than two times per second. Otherwise, the fuel gauge could result in a reset issue due to the expiration of the watchdog timer.

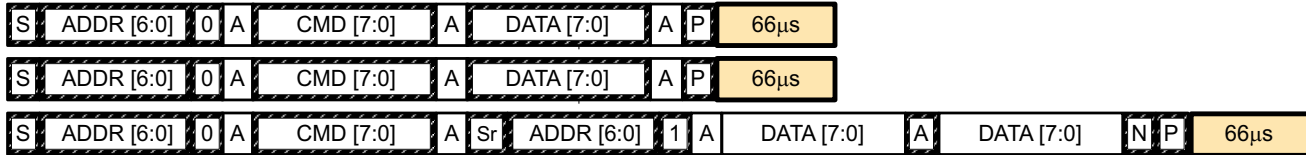

Waiting time inserted between two 1-byte write packets for a subcommand and reading results (required for  $100 \text{ kHz} < f_{SCL} \leq 400 \text{ kHz}$ )

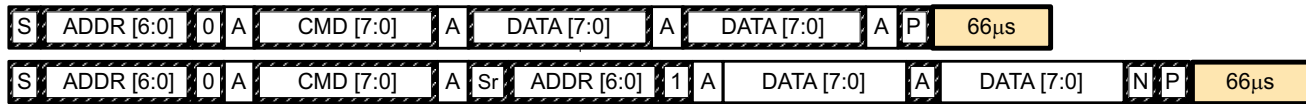

Waiting time inserted between incremental 2-byte write packet for a subcommand and reading results (acceptable for  $f_{SCL} \leq 100 \text{ kHz}$ )

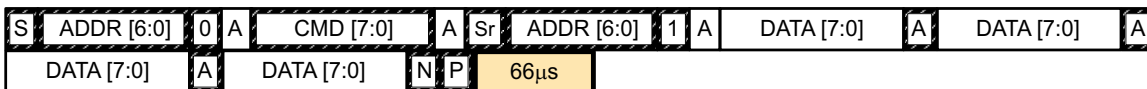

Waiting time inserted after incremental read

### I<sup>2</sup>C Clock Stretching

A clock stretch can occur during all modes of fuel gauge operation. In SLEEP and HIBERNATE modes, a short clock stretch occurs on all I<sup>2</sup>C traffic as the device must wake-up to process the packet. In the other modes (BAT INSERT CHECK, NORMAL) clock stretching only occurs for packets addressed for the fuel gauge. The majority of clock stretch periods are small as the I<sup>2</sup>C interface performs normal data flow control. However, less frequent yet more significant clock stretch periods may occur as blocks of Data Flash are updated. The following table summarizes the approximate clock stretch duration for various fuel gauge operating conditions.

Gauging Mode	Operating Condition or Comment	Approximate Duration
SLEEP HIBERNATE	Clock stretch occurs at the beginning of all traffic as the device wakes up.	$\leq 4 \text{ ms}$
BAT INSERT CHECK, NORMAL	Clock stretch occurs within the packet for flow control (after a start bit, ACK or first data bit).	$\leq 4 \text{ ms}$
	Normal Ra table Data Flash updates.	24 ms
	Data Flash block writes.	72 ms
	Restored Data Flash block write after loss of power.	116 ms
	End of discharge Ra table Data Flash update.	144 ms

REFERENCE SCHEMATICS

SCHEMATIC

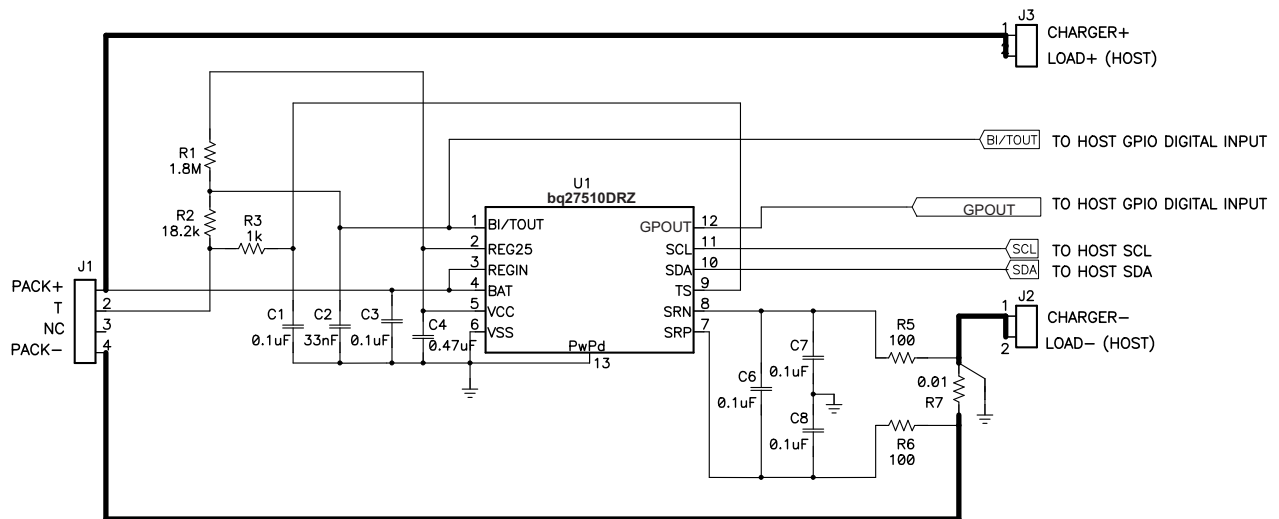

**PACKAGING INFORMATION**

Orderable Device	Status (1)	Package Type	Package Drawing	Pins	Package Qty	Eco Plan (2)	Lead/Ball Finish	MSL Peak Temp (3)	Op Temp (°C)	Top-Side Markings (4)	Samples
BQ27510DRZR-G3	ACTIVE	SON	DRZ	12	3000	Green (RoHS & no Sb/Br)	CU NIPDAU	Level-2-260C-1 YEAR	-40 to 85	BQ 7510	<a href="#">Samples</a>
BQ27510DRZT-G3	ACTIVE	SON	DRZ	12	250	TBD	Call TI	Call TI	-40 to 85	BQ 7510	<a href="#">Samples</a>

(1) The marketing status values are defined as follows:

**ACTIVE:** Product device recommended for new designs.

**LIFEBUY:** TI has announced that the device will be discontinued, and a lifetime-buy period is in effect.

**NRND:** Not recommended for new designs. Device is in production to support existing customers, but TI does not recommend using this part in a new design.

**PREVIEW:** Device has been announced but is not in production. Samples may or may not be available.

**OBSOLETE:** TI has discontinued the production of the device.

(2) Eco Plan - The planned eco-friendly classification: Pb-Free (RoHS), Pb-Free (RoHS Exempt), or Green (RoHS & no Sb/Br) - please check <http://www.ti.com/productcontent> for the latest availability information and additional product content details.

**TBD:** The Pb-Free/Green conversion plan has not been defined.

**Pb-Free (RoHS):** TI's terms "Lead-Free" or "Pb-Free" mean semiconductor products that are compatible with the current RoHS requirements for all 6 substances, including the requirement that lead not exceed 0.1% by weight in homogeneous materials. Where designed to be soldered at high temperatures, TI Pb-Free products are suitable for use in specified lead-free processes.

**Pb-Free (RoHS Exempt):** This component has a RoHS exemption for either 1) lead-based flip-chip solder bumps used between the die and package, or 2) lead-based die adhesive used between the die and leadframe. The component is otherwise considered Pb-Free (RoHS compatible) as defined above.

**Green (RoHS & no Sb/Br):** TI defines "Green" to mean Pb-Free (RoHS compatible), and free of Bromine (Br) and Antimony (Sb) based flame retardants (Br or Sb do not exceed 0.1% by weight in homogeneous material)

(3) MSL, Peak Temp. -- The Moisture Sensitivity Level rating according to the JEDEC industry standard classifications, and peak solder temperature.

(4) Multiple Top-Side Markings will be inside parentheses. Only one Top-Side Marking contained in parentheses and separated by a "~" will appear on a device. If a line is indented then it is a continuation of the previous line and the two combined represent the entire Top-Side Marking for that device.

**Important Information and Disclaimer:** The information provided on this page represents TI's knowledge and belief as of the date that it is provided. TI bases its knowledge and belief on information provided by third parties, and makes no representation or warranty as to the accuracy of such information. Efforts are underway to better integrate information from third parties. TI has taken and continues to take reasonable steps to provide representative and accurate information but may not have conducted destructive testing or chemical analysis on incoming materials and chemicals. TI and TI suppliers consider certain information to be proprietary, and thus CAS numbers and other limited information may not be available for release.

In no event shall TI's liability arising out of such information exceed the total purchase price of the TI part(s) at issue in this document sold by TI to Customer on an annual basis.

DRZ (S-PDSO-N12)

PLASTIC SMALL OUTLINE

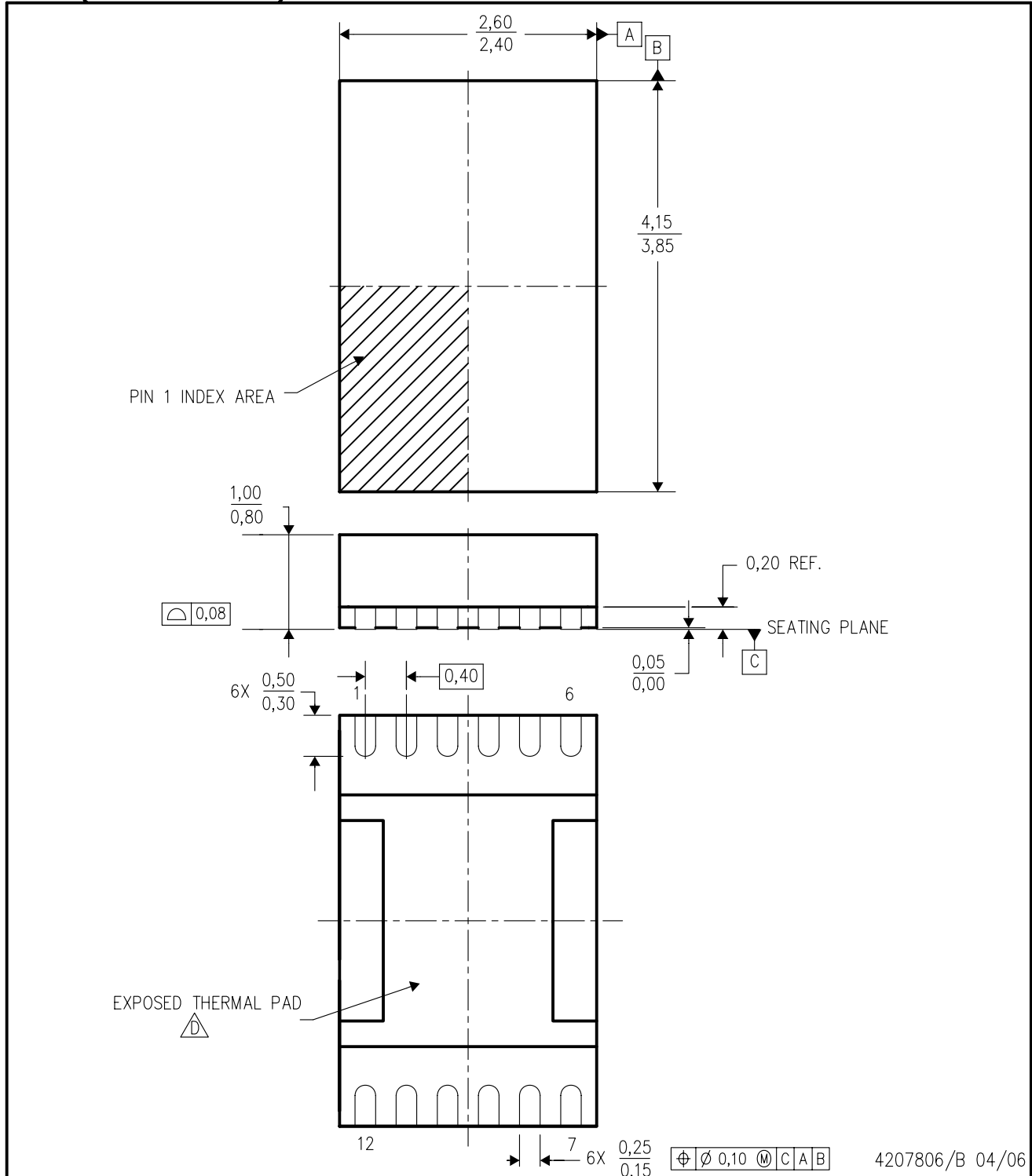

- NOTES:
- A. All linear dimensions are in millimeters. Dimensioning and tolerancing per ASME Y14.5M-1994.
  - B. This drawing is subject to change without notice.
  - C. Small Outline No-Lead (SON) package configuration.
  -  The package thermal pad must be soldered to the board for thermal and mechanical performance. See the Product Data Sheet for details regarding the exposed thermal pad dimensions.
  - E. This package is lead-free.

## THERMAL PAD MECHANICAL DATA

DRZ (R-PDSO-N12)

PLASTIC SMALL OUTLINE NO-LEAD

### THERMAL INFORMATION

This package incorporates an exposed thermal pad that is designed to be attached directly to an external heatsink. The thermal pad must be soldered directly to the printed circuit board (PCB). After soldering, the PCB can be used as a heatsink. In addition, through the use of thermal vias, the thermal pad can be attached directly to the appropriate copper plane shown in the electrical schematic for the device, or alternatively, can be attached to a special heatsink structure designed into the PCB. This design optimizes the heat transfer from the integrated circuit (IC).

For information on the Quad Flatpack No-Lead (QFN) package and its advantages, refer to Application Report, QFN/SON PCB Attachment, Texas Instruments Literature No. SLUA271. This document is available at [www.ti.com](http://www.ti.com).

The exposed thermal pad dimensions for this package are shown in the following illustration.

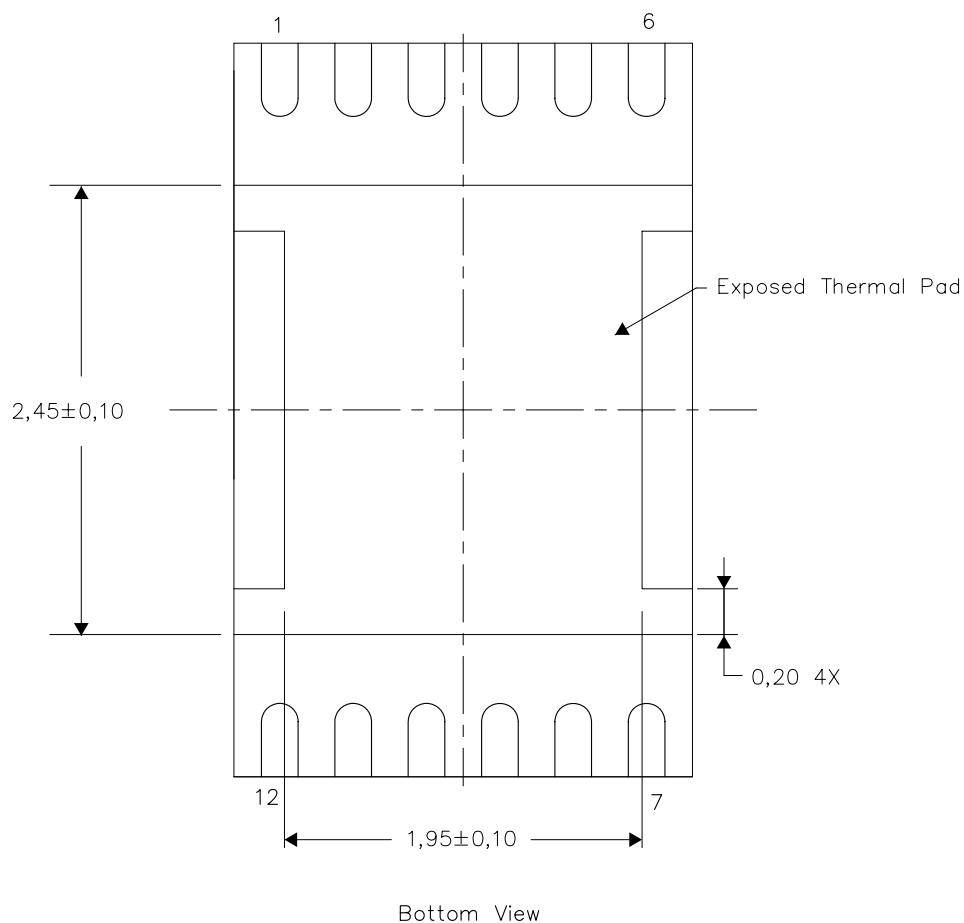

NOTE: All linear dimensions are in millimeters

Exposed Thermal Pad Dimensions

4208114/E 06/10

DRZ (S-PDSO-N12)

PLASTIC SMALL OUTLINE NO-LEAD

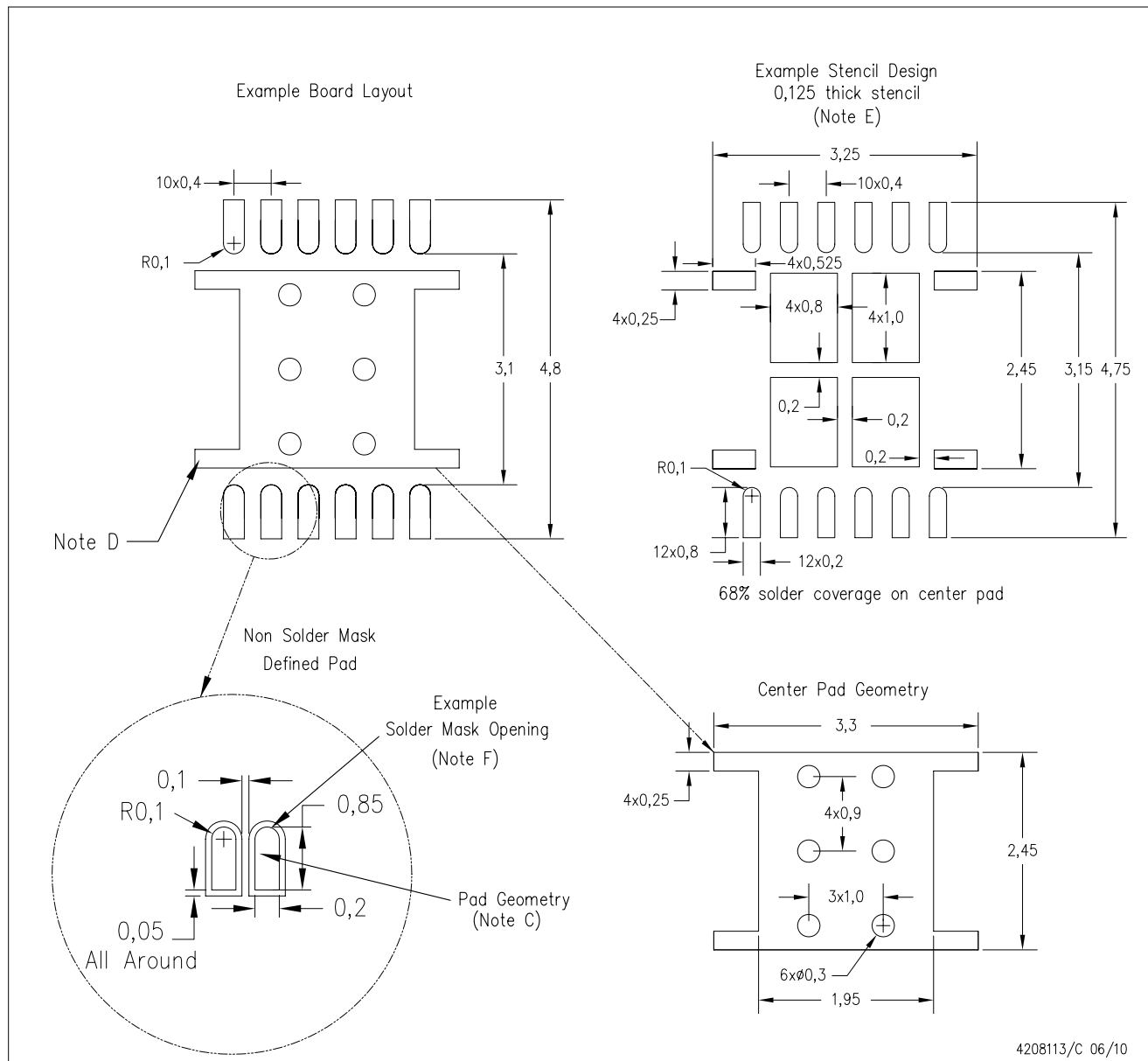

4208113/C 06/10

- NOTES:
- All linear dimensions are in millimeters.
  - This drawing is subject to change without notice.
  - Publication IPC-7351 is recommended for alternate designs.
  - This package is designed to be soldered to a thermal pad on the board. Refer to Application Note, Quad Flat-Pack Packages, Texas Instruments Literature No. SCBA017, SLUA271, and also the Product Data Sheets for specific thermal information, via requirements, and recommended board layout. These documents are available at [www.ti.com](http://www.ti.com) <<http://www.ti.com>>.
  - Laser cutting apertures with trapezoidal walls and also rounding corners will offer better paste release. Customers should contact their board assembly site for stencil design recommendations. Refer to IPC 7525 for stencil design considerations.
  - Customers should contact their board fabrication site for minimum solder mask web tolerances between signal pads.

## IMPORTANT NOTICE

Texas Instruments Incorporated and its subsidiaries (TI) reserve the right to make corrections, enhancements, improvements and other changes to its semiconductor products and services per JESD46, latest issue, and to discontinue any product or service per JESD48, latest issue. Buyers should obtain the latest relevant information before placing orders and should verify that such information is current and complete. All semiconductor products (also referred to herein as "components") are sold subject to TI's terms and conditions of sale supplied at the time of order acknowledgment.

TI warrants performance of its components to the specifications applicable at the time of sale, in accordance with the warranty in TI's terms and conditions of sale of semiconductor products. Testing and other quality control techniques are used to the extent TI deems necessary to support this warranty. Except where mandated by applicable law, testing of all parameters of each component is not necessarily performed.

TI assumes no liability for applications assistance or the design of Buyers' products. Buyers are responsible for their products and applications using TI components. To minimize the risks associated with Buyers' products and applications, Buyers should provide adequate design and operating safeguards.

TI does not warrant or represent that any license, either express or implied, is granted under any patent right, copyright, mask work right, or other intellectual property right relating to any combination, machine, or process in which TI components or services are used. Information published by TI regarding third-party products or services does not constitute a license to use such products or services or a warranty or endorsement thereof. Use of such information may require a license from a third party under the patents or other intellectual property of the third party, or a license from TI under the patents or other intellectual property of TI.

Reproduction of significant portions of TI information in TI data books or data sheets is permissible only if reproduction is without alteration and is accompanied by all associated warranties, conditions, limitations, and notices. TI is not responsible or liable for such altered documentation. Information of third parties may be subject to additional restrictions.

Resale of TI components or services with statements different from or beyond the parameters stated by TI for that component or service voids all express and any implied warranties for the associated TI component or service and is an unfair and deceptive business practice. TI is not responsible or liable for any such statements.

Buyer acknowledges and agrees that it is solely responsible for compliance with all legal, regulatory and safety-related requirements concerning its products, and any use of TI components in its applications, notwithstanding any applications-related information or support that may be provided by TI. Buyer represents and agrees that it has all the necessary expertise to create and implement safeguards which anticipate dangerous consequences of failures, monitor failures and their consequences, lessen the likelihood of failures that might cause harm and take appropriate remedial actions. Buyer will fully indemnify TI and its representatives against any damages arising out of the use of any TI components in safety-critical applications.

In some cases, TI components may be promoted specifically to facilitate safety-related applications. With such components, TI's goal is to help enable customers to design and create their own end-product solutions that meet applicable functional safety standards and requirements. Nonetheless, such components are subject to these terms.

No TI components are authorized for use in FDA Class III (or similar life-critical medical equipment) unless authorized officers of the parties have executed a special agreement specifically governing such use.

Only those TI components which TI has specifically designated as military grade or "enhanced plastic" are designed and intended for use in military/aerospace applications or environments. Buyer acknowledges and agrees that any military or aerospace use of TI components which have **not** been so designated is solely at the Buyer's risk, and that Buyer is solely responsible for compliance with all legal and regulatory requirements in connection with such use.

TI has specifically designated certain components as meeting ISO/TS16949 requirements, mainly for automotive use. In any case of use of non-designated products, TI will not be responsible for any failure to meet ISO/TS16949.

### Products

Audio	<a href="http://www.ti.com/audio">www.ti.com/audio</a>
Amplifiers	<a href="http://amplifier.ti.com">amplifier.ti.com</a>
Data Converters	<a href="http://dataconverter.ti.com">dataconverter.ti.com</a>
DLP® Products	<a href="http://www.dlp.com">www.dlp.com</a>
DSP	<a href="http://dsp.ti.com">dsp.ti.com</a>
Clocks and Timers	<a href="http://www.ti.com/clocks">www.ti.com/clocks</a>
Interface	<a href="http://interface.ti.com">interface.ti.com</a>
Logic	<a href="http://logic.ti.com">logic.ti.com</a>
Power Mgmt	<a href="http://power.ti.com">power.ti.com</a>
Microcontrollers	<a href="http://microcontroller.ti.com">microcontroller.ti.com</a>
RFID	<a href="http://www.ti-rfid.com">www.ti-rfid.com</a>
OMAP Applications Processors	<a href="http://www.ti.com/omap">www.ti.com/omap</a>
Wireless Connectivity	<a href="http://www.ti.com/wirelessconnectivity">www.ti.com/wirelessconnectivity</a>

### Applications

Automotive and Transportation	<a href="http://www.ti.com/automotive">www.ti.com/automotive</a>
Communications and Telecom	<a href="http://www.ti.com/communications">www.ti.com/communications</a>
Computers and Peripherals	<a href="http://www.ti.com/computers">www.ti.com/computers</a>
Consumer Electronics	<a href="http://www.ti.com/consumer-apps">www.ti.com/consumer-apps</a>
Energy and Lighting	<a href="http://www.ti.com/energy">www.ti.com/energy</a>
Industrial	<a href="http://www.ti.com/industrial">www.ti.com/industrial</a>
Medical	<a href="http://www.ti.com/medical">www.ti.com/medical</a>
Security	<a href="http://www.ti.com/security">www.ti.com/security</a>
Space, Avionics and Defense	<a href="http://www.ti.com/space-avionics-defense">www.ti.com/space-avionics-defense</a>
Video and Imaging	<a href="http://www.ti.com/video">www.ti.com/video</a>

### TI E2E Community

[e2e.ti.com](http://e2e.ti.com)